

**DRIES
WET FLOORS**

HURRICONE

Cordless Floor Dryer



BE PROACTIVE ABOUT FLOOR SAFETY

★ NEW FEATURE ★



Battery Level Indicator

★ NEW ACCESSORY ★



Flashing LED Light

★ NEW ACCESSORY ★



Octagon Warning Sign

- Dries floors 360 degrees around unit and up to 15 feet in diameter (177 sq. ft.)
- Cordless / Rechargeable - Runs up to 12 hours on a replaceable battery pack
- Decrease your floor drying time by up to 90%*
- Battery Level Indicator ★NEW★ LED and Audible warnings of low battery voltage
- Battery Saver Circuit ★NEW★ Automatically limits battery discharge to optimize battery life
- Battery pack can be charged internally or removed and charged separately to avoid taking floor dryer out of service
- Safety cones can be stacked for easy storage and transport
- Fits HURRICONE™ Brand, Rubbermaid®, and Lamba Systems® 36 in. safety cones
- HURRICONE™ Brand safety cone meets new OSHA and ANSI standards ★NEW★
- 1 Year Warranty

The National Safety Council Reports 9 Million
Disabling Slip & Fall Accidents Occur Each Year =

25,000 SLIP & FALL ACCIDENTS DAILY



US & Foreign Patents Pending

**Demo
Program
Available**

SLIP & FALL FACTS

- Approximately 25,000 People a Day Are Victims to Slip and Fall Accidents. The Expense of These Injuries is Running \$3.5 Million per Hour, Every Hour of the Day, Every Day of the Year. That's over \$30 Billion Per Year (Source: National Safety Council)
- The Average Cost of a Slip and Fall Injury Exceeds \$12,000 (Source: Wausau Insurance)
- The Average Cost to Defend a Slip and Fall Lawsuit is \$50,000 (Source: National Floor Safety Institute)
- Plaintiffs Win 51% of Premises Liability Claims (Source: Jury Verdict Research)
- Slips and Falls are the #1 Cause of Accidents in Hotels, Restaurants & Public Buildings, 70% of these Accidents Occur on Flat/Level Surfaces (Source: Bureau of Labor Statistics)
- Our Nation's \$494 Billion Grocery Store Industry Spends \$450 Million Annually to Defend Slip and Fall Claims (Source: National Floor Safety Institute)

Hurricane™ Specifications

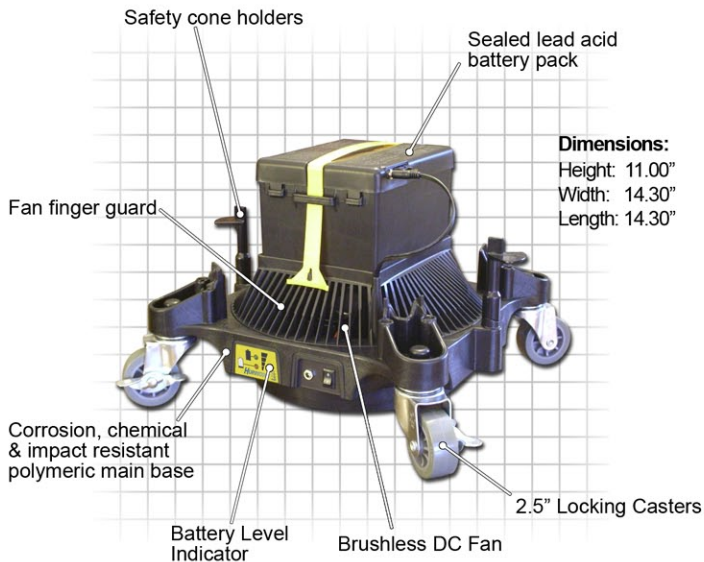

Dimensions:
 Height: 11.00"
 Width: 14.30"
 Length: 14.30"

Facilities to use the Hurricane™

- Airports
- Amusement Parks
- Convention Centers
- Educational Facilities
 - Schools, Libraries, Daycare Centers
- Food Service
 - Restaurants, Grocery Stores, Fast Food
- HealthCare
 - Hospitals, Nursing Homes, Doctors Offices, Exercise Facilities
- Industrial / Manufacturing Facilities
- Lodging
 - Hotels, Motels, Resorts
- Office Buildings / Banks
- Retail
 - Department Stores, Malls, Gas Stations, Convenience Stores
- Entertainment Complexes
 - Stadiums, Sports Complex, Arenas, Theaters, Museums

Fan



- 50,000 hour long life brushless DC motor
- High CFM airflow
- Housing - aluminum
- Impeller - Thermoplastic PBT
- Low current draw
- High efficiency

Battery



- 12 volt sealed lead acid (SLA) high rate series
- Absorbent Glass Mat (AGM) technology for superior performance
- Rugged polymeric case & cover
- 350 - 500 charging cycles
- 5 Amp Fuse
- Non-spillable
- Approved for transport by air DOT, IATA, FAA & CAB approved
- UL recognized and carries the CE mark

Charger



- Electronically regulated
- Smart charger circuitry: eliminates the need to unplug the unit after charging.
- Dual rate charger senses battery requirements and automatically switches from fast charge to float (standby) mode
- UL, UL-C listed and carries the CE mark
- 110/240 Dual Voltage

Battery Level Indicator



- LED and Audible warnings of low battery voltage
- Battery Saver Circuit automatically limits battery discharge to optimize battery life



Areas to use the Hurricane™

- High Traffic Areas
 - Entryways, Lobbies, Hallways
- Restrooms
- Self-Serve Beverage / Food Areas
- Dining Areas
- Kitchen Areas
- Locker Room / Shower Areas
- Factory Floor

Shipping Size / Weight: H 8.5", W 15.0", L 24.0" / 31 lbs.

Visit Hurricane.com for latest accessories

* Based on actual drying area using Hurricane™ on hard surfaces.



<http://www.hurricane.com>